

FOCUS PEEM

PHOTOEMISSION ELECTRON MICROSCOPE

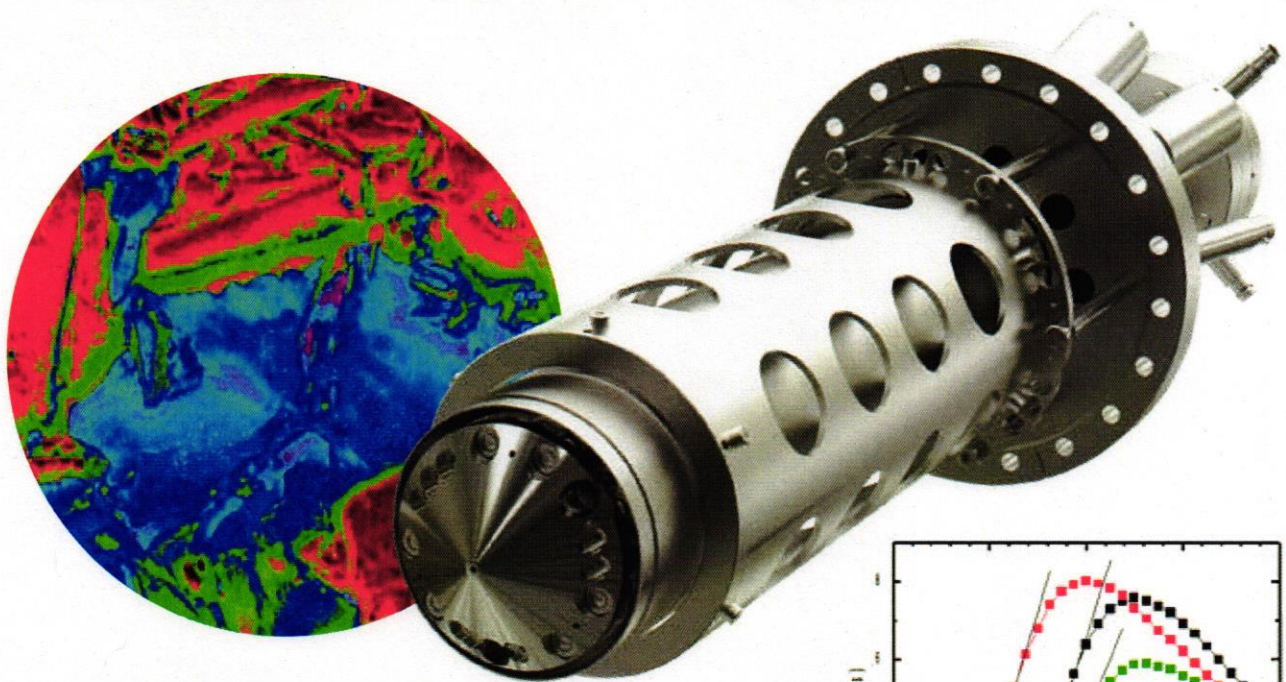

Brochure

WORKFUNCTION MAPPING

MICROSCOPIC ARPES (μ -ARPES)

MOMENTUM MICROSCOPY / K-SPACE IMAGING

IMAGING XAS (μ -XAS)

TIME OF FLIGHT (TOF) MICROSCOPY

IMAGING ESCA

MAGNETIC IMAGING (XMCD)

HARD X-RAY PEEM (HAXPEEM)

SPIN RESOLVED MOMENTUM MICROSCOPY

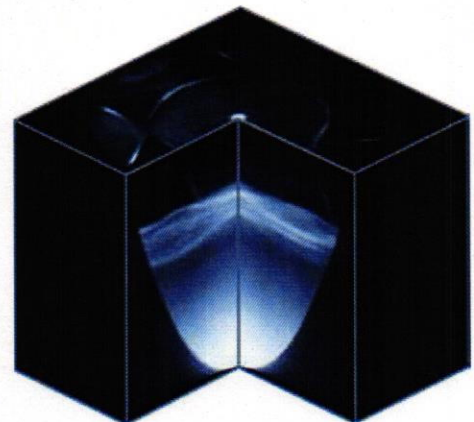
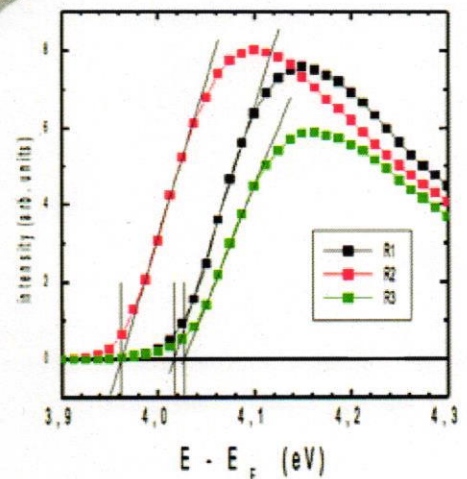

INTRODUCTION

Brochure



FOCUS engagement with the PEEM dates back into 1996. Today almost 90 of our instruments are operated world wide. From the very first day we took all the customer feed-back to constantly improve the performance and ease of use of our microscopes.

The FOCUS PEEM utilizes the technique of photoemission electron microscopy to image electrons emitted from any flat and conducting sample surface.

Electron emission from surfaces can be caused by UV, VUV or x-ray photons, by thermal activation, by electron/ion bombardment or even by field emission.

The FOCUS PEEM together with the dedicated high stability integrated sample stage (IS) and various available energy filters provides an easy to upgrade modular concept.

Today the FOCUS PEEM is designed to combine both real- and k-space imaging together with energy filtering and hence spectroscopic microscopy („spectromicroscopy“) at its best.



FOCUS is permanently keeping a close contact to the scientific community.

An essential and ongoing highlight in case of PEEM instrumentation is our FOCUS PEEM workshop taking place every two years at our premises.

This workshop is addressed to all researchers who are interested in PEEM techniques and its capabilities including theory and working practices. Its private atmosphere allows to discuss individual questions directly with our R&D and application experts throughout the entire workshop.

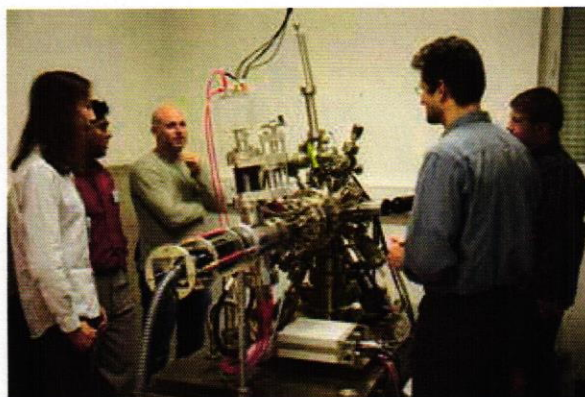

THE MICROSCOPE: LAYOUT AND APPLICATION RANGE

The objective lens is designed as an electrostatic immersion lens to collect electrons from 0.0 eV up to 1.6 keV (HAXPEEM: up to 10 keV, see page 9).

The remaining FOCUS PEEM lens system works also purely electrostatic in order to avoid interferences with magnetic surfaces as well as any image and/or spin rotation while an energy scan is performed.

Software assisted control ensures time efficient and safe PEEM operation even on challenging samples (ProNanoESCA™, see page 11).

The calculated electron optical resolution is better than 20 nm. The electromagnetic field distribution near to the sample surface and/or simply a limited photon density are determining the obtainable resolution on a real sample in practice.

The FOCUS IS-PEEM is designed to be operated with the piezo driven high stability integrated sample stage (IS) and various energy filters following an easy to upgrade modular concept (See page 4).

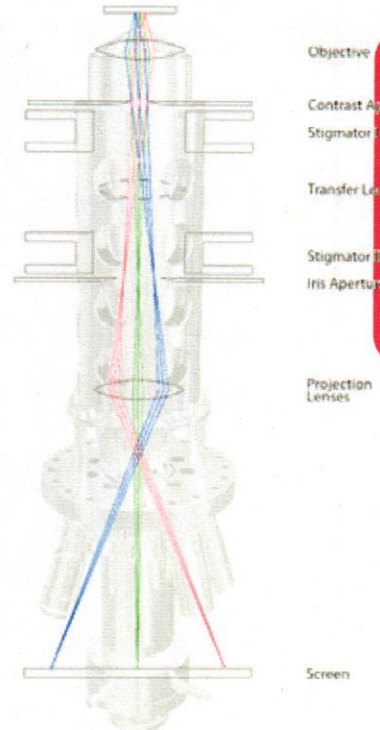

Brochure

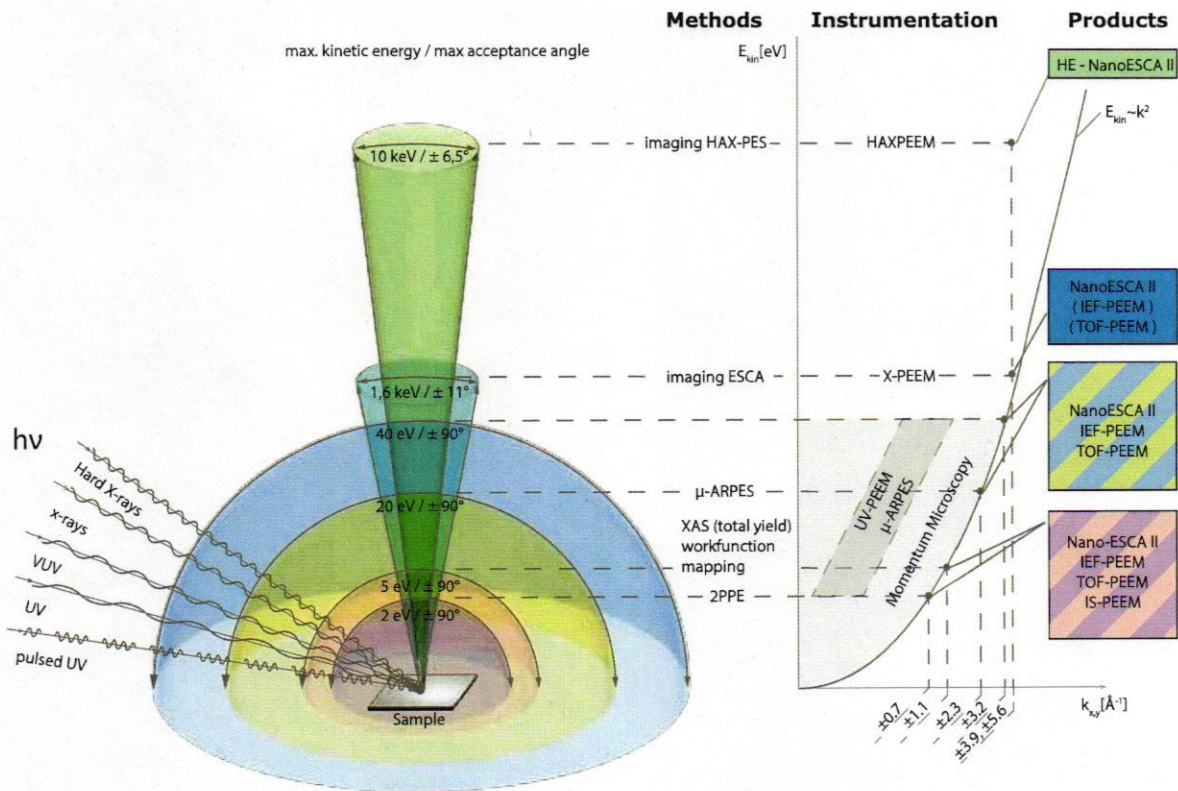

PEEM and its field of parameters and applications:
Photon energy, emission energy & angle and the k-space horizon
vs. dedicated instrumentation

ENERGY FILTERING: GETTING MORE OUT OF A PEEM!

Energy filtering allows to image photoelectrons of specific energies both in real and in k-space mode. Additionally energy filtering is improving the lateral resolution of the PEEM by reducing the chromatic aberrations of the electron optics caused by the energy spread of the imaged electrons.

The imaging energy filter (IEF) acts as an imaging high pass filter. It represents a compact and versatile energy filter for all applications at low binding energies.

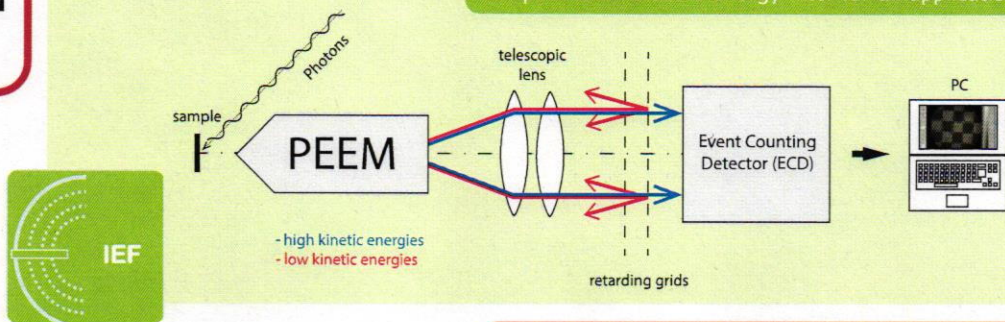

If the experiment features a pulsed sample emission by using a pulsed laser or synchrotron light, the retractable TOF/DLD detector should be taken into account. It can be used alternately with the IEF in one instrument.

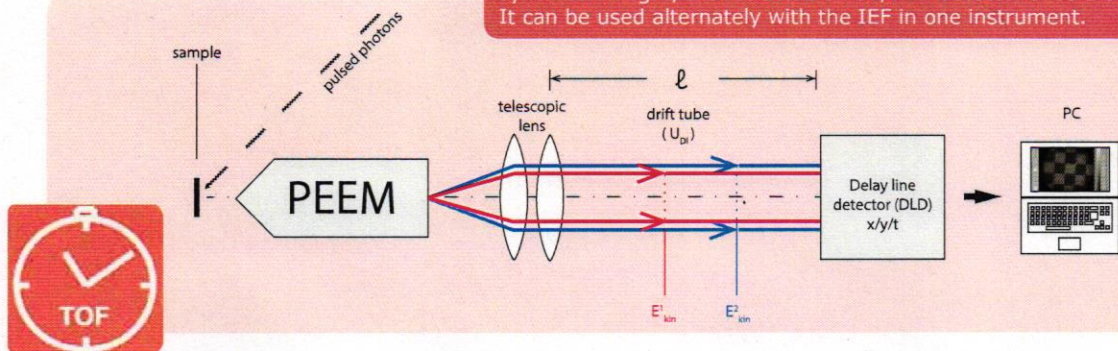

A recent development is the combination of an imaging bandpass, like e.g. the IDEA and the TOF-Setup, called xTOF-PEEM, which reveals an ultimate performance of the TOF-PEEM at higher binding energies.

The NanoESCA III core element consists of the patented IDEA (Imaging Dispersive Energy Analyser). Its double hemisphere design exhibits a real energy dispersive approach together with an unrevealed real and k-space imaging quality

(D. Funnemann, M. Escher, European Patent EP 1 559 126 B1, US patent US 7 250 599 B2).

Aberration compensated band pass filter: Besides elimination of the analyser's spherical aberration, the tandem arrangement also largely retains the time structure of the electron signal, unlike a single hemispherical analyser which can be helpful with time resolving experiments.

A special version of the NanoESCA III -the HAXPEEM- is capable to be operated at up to 10keV using hard x-rays (see page 9).

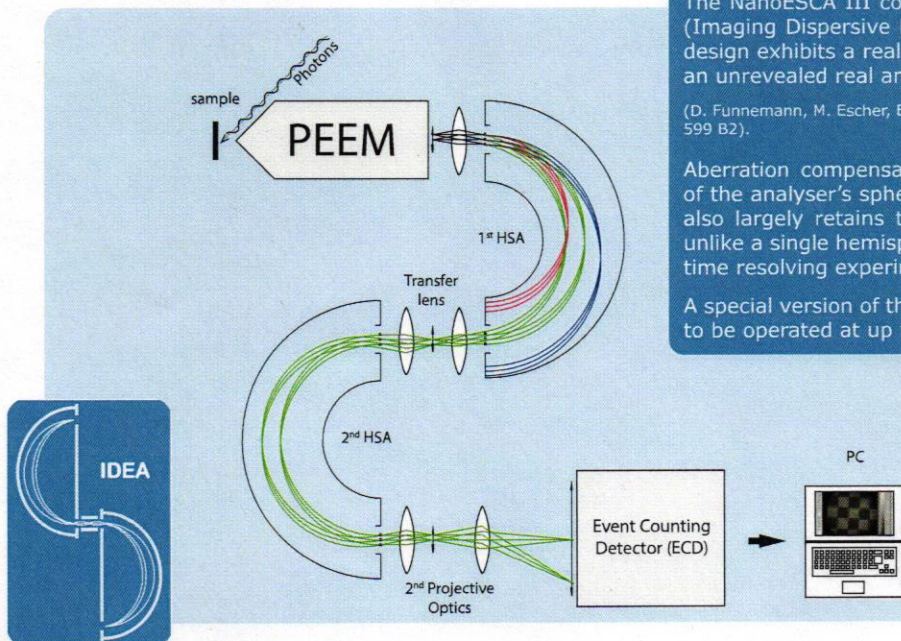

The NanoESCA III is distributed exclusively by Scienta Omicron. Please contact them for more informations and/or refer to the related web page <http://www.scientaomicron.com>

ENERGY FILTERING: APPLICATIONS

IEF (Imaging Energy Filter):

The IEF is operated like a retarding field analyser upon conserving the full image quality at the same time. From this it acts as an imaging high pass filter. It represents a compact and versatile energy filter for all applications with good photoelectron yield and at low binding energies. The obtainable energy resolution is < 50 meV.

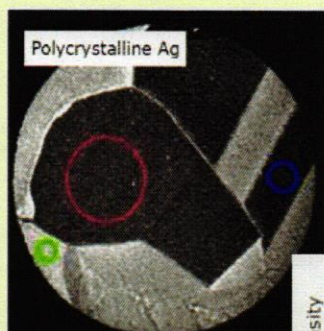

TOP: Threshold emission of poly crystalline silver using PEEM with IEF and Hg UV-source, reveals a workfunction map.

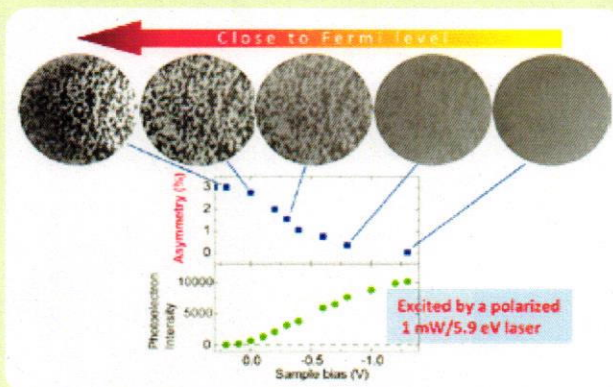
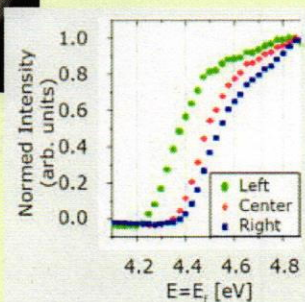

Top: Using a polarized UV laser for excitation reveals magnetic domain imaging close to the Fermi edge.

Data courtesy of Takeshi Nakagawa, Department of Molecular and Material Sciences, Kyushu University, Kasuga, Fukuoka 816-8580, Japan

TOF/DLD (time-of-flight):

Using a pulsed laser or synchrotron beam line allows to exploit the benefits of TOF-PEEM for time resolved imaging with an overall time resolution down to 180 ps used for parallel energy filtering by converting the time slices into energy slices with an energy resolution < 50 meV.

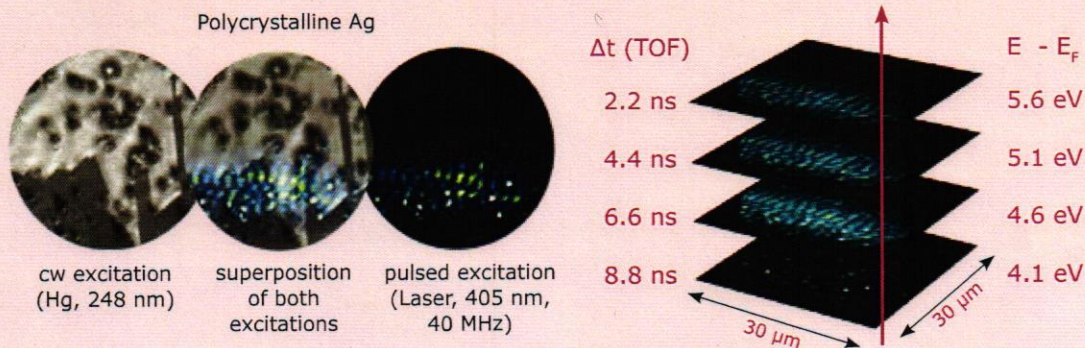

Plasmons on polycrystalline silver using pulsed LASER excitation. Measured with TOF-PEEM. Left: UV PEEM and Laser PEEM imaging; right: x/y time image stack

MOMENTUM MICROSCOPY: FROM REAL- TO k-SPACE IMAGING

Energy filtered PEEM with the k-space option is the ideal instrument to navigate in real space to areas of interest and then switch with one mouse click in between real space- and k-space imaging.

For this the PEEM lens can be equipped optionally with additional electron optical elements to accomplish not only the lateral imaging but also the imaging of the momentum distribution of the emitted electrons.

This concept has been called Momentum Microscope and is implemented both with the TOF PEEM and the NanoESCA III as a standard. Also the IEF PEEM can be equipped with this k-space optics optionally (AD option).

ELECTRON OPTICAL LAYOUT:

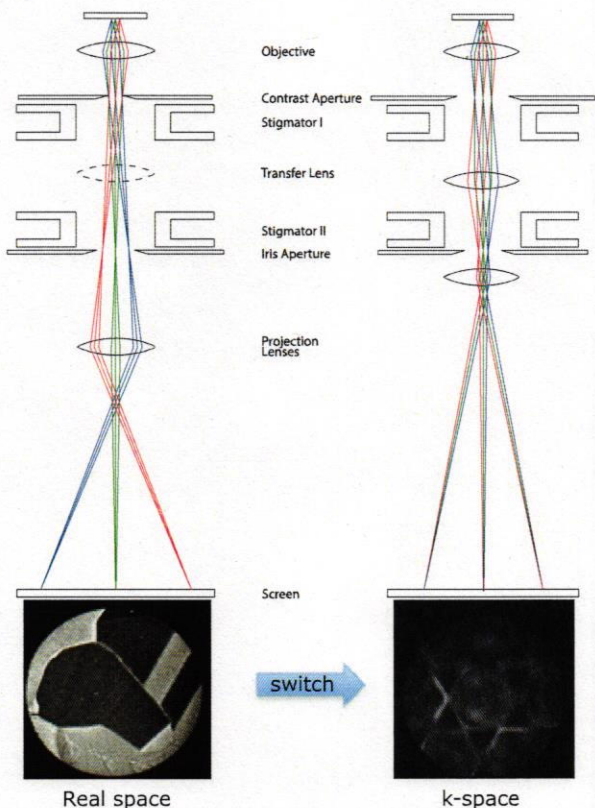

Both figures on the left show a sketch of the electron optical ray tracing from the sample (top) down to the imaging detector (bottom). The left hand figure illustrates the set-up causing a microscopic real space image. All electrons emitted from lateral sample sites within the microscopic field of view (FoV) are imaged onto the detector with the chosen magnification.

The right hand scheme represents the imaging of the angular distribution (k-space, momentum distribution) of the photo electrons emitted by the sample. The variable iris aperture is used to define the source area for k-space imaging down to less than 5 μm .

Together with an appropriate energy filter (recommended) it is possible by this means to switch from real space imaging to k-space imaging and vice versa all the time. The angular distribution of the emitted electrons originating from a certain real space field of view are imaged in parallel for the k_x and k_y direction and a certain chosen energy E at once.

This kind of μ -ARPES is illustrated on a silver sample on the left.

By sweeping the energy E of the imaged electrons it becomes possible to get the whole k_x - k_y - E image stack. This image stack represents a complete 3D-image of the band structure of a crystalline sample (right: data cube of the Ag(111) band structure acquired with the NanoESCA III).

The maximum FoV in the k-space depends upon the excitation energy applied. For He I excitation (21.2 eV) an FoV of about 3 \AA^{-1} is achieved. Using He II photons (40.8 eV) the k-space FoV is expanded to about 6 \AA^{-1} .

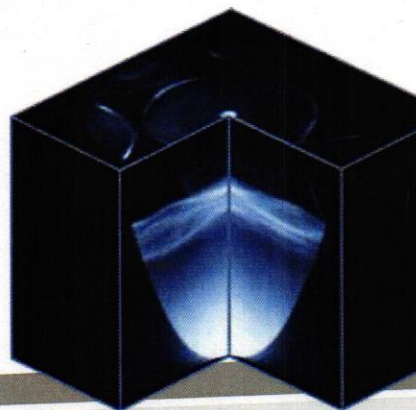



IEF PEEM & VUV lab source HIS 14 HD

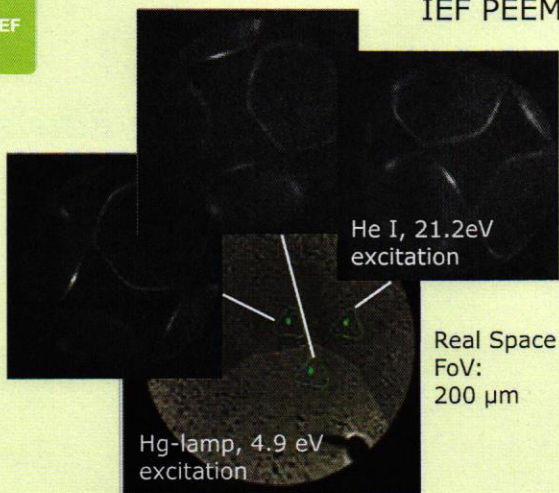

Left: μ -ARPES of polycrystalline silver. The navigation in the real space is accomplished by use of the iris micro aperture defining the region of interest before switching to k-space imaging.

Because of their different crystallographic orientation the single grains deliver different momentum patterns.

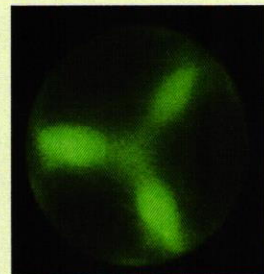

Top: Imaging of the d-band region of Ag(111), He I excitation (HIS 14 HD, 21.2 eV), $E-E_F = 15.5$ eV, dwell time 5 s, sample region $\sim 20 \mu\text{m}$



TOF PEEM & Pulsed Laser

The complete k-space of the photoemission from a Au (111) surface (@room temperature), has been excited with a pulsed 210 nm laser (80 MHz rep. rate, $200 \times 200 \mu\text{m}^2$, $17 \mu\text{W}$); Surface state and direct sp-sp transitions.

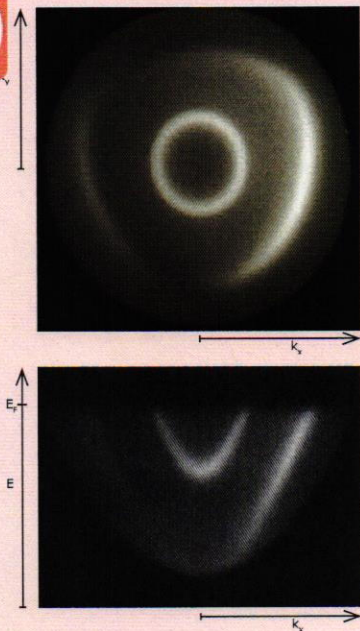

Top left:

k_x - k_y image near to the Fermi energy E_F .

Bottom left:

E - k_x image with a sharp parabolic emission horizon.

Right:

3D representation of a complete E - k_x - k_y data cube.

Real space FoV: about $25 \mu\text{m}$

k -space FoV: $\pm 0.575 \text{ \AA}^{-1}$

drift energy: 20 eV

energy range: 4.3 eV to 5.9 eV (E_F)

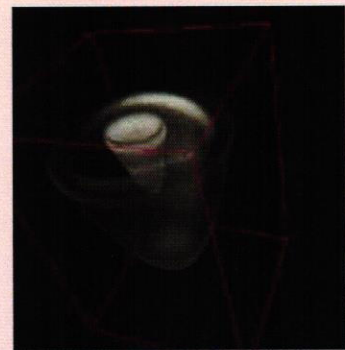

NanoESCA III & VUV source

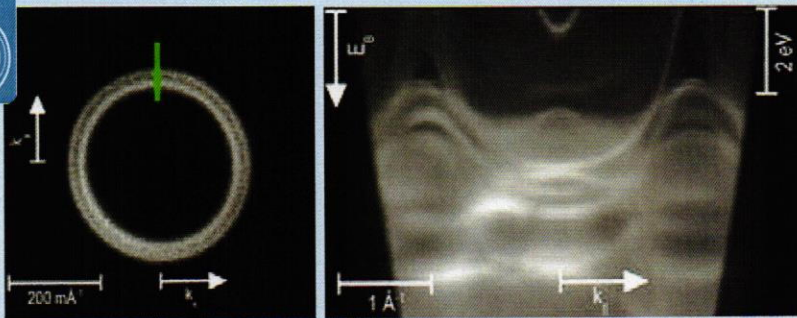

$k_{||}$ display of the surface state with Rashba splitting at the Fermi energy.

E over $k_{||}$ display (logarithmic scale): Band structure $M'-G-M$ and surface state.

The Au(111) surface state was recorded at the Fermi edge with the sample cooled down to 30 K. The instrument resolution was set to 50 meV. Excitation was HeI (21.2 eV, HIS14). A complete E - k_x - k_y data stack was acquired and a k_x - k_y zoom to the surface state at the Fermi edge taken.

NanoESCA III: A MULTI-TECHNIQUES TOOL!

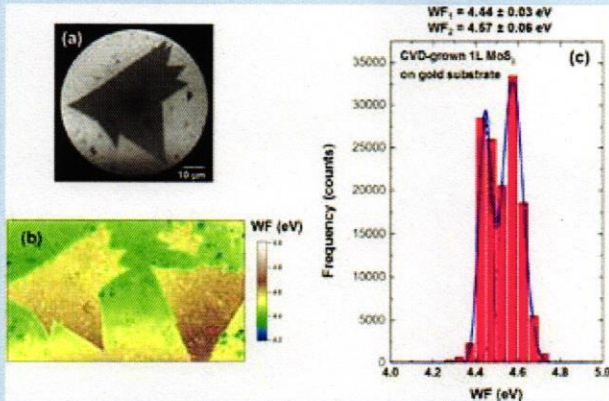

UV-PEEM

- Left: (a) Energy filtered PEEM image ($E-E_F = 4.5$ eV, field of view of $67 \mu\text{m}$) of a MoS_2 1L domain transferred onto Au substrate.
 (b) Corresponding workfunction map within a field of view of $115 \mu\text{m}$ and
 (c) WF distribution histogram.



Imaging XPS

Imaging ESCA(XPEEM) with soft x-rays up to 1600 eV delivers an ultimate lateral resolution down to below 150 nm. UV-PEEM accomplishes detailed work function studies of the same sample and enables a lateral resolution of less than 20 nm.

- Right: (a) Energy filtered PEEM image (threshold, $E-E_F = 3.3$ eV) of a MoS_2 1L domain transferred onto Si substrate and
 (b) corresponding XPS survey micro-spectrum.
 (c) Integrated Mo 3d (BE 230 eV),
 (d) S 2p (BE 163 eV), and
 (e) Si 2p (BE 103 eV) core level peak area image of the identical region as the one shown in (a).

The corresponding high-resolution spectra with component peak fitting are presented at the bottom. The peaks were fitted using the asymmetric/symmetric Voigt functions using CASA XPS software.

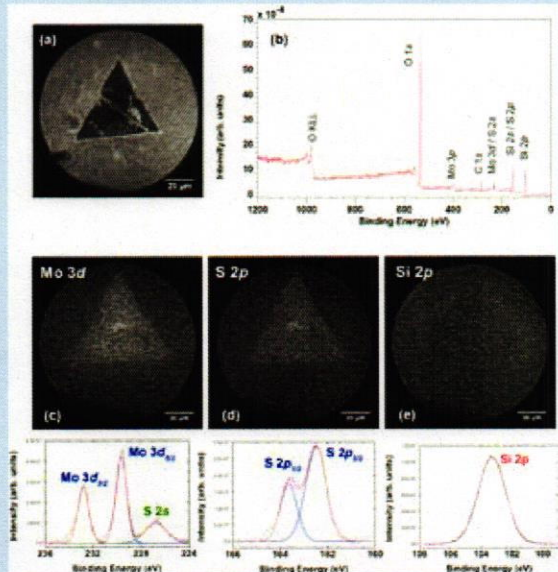

Momentum Microscopy

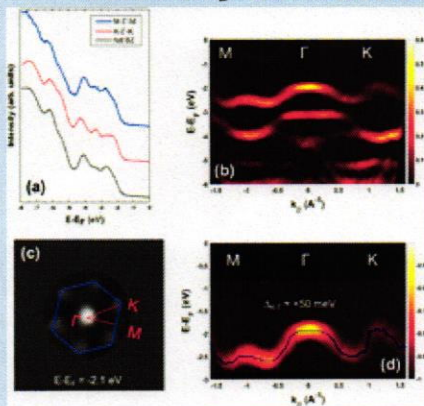

- Left: (a) Angle-integrated valence band spectra of CVD-grown MoS_2 1L on SiO_2/Si extracted along the high-symmetry directions ($\text{M}\Gamma\text{M}$) and ($\text{K}\Gamma\text{K}$) of the BZ and over the full BZ.
 (b) Energy filtered k-PEEM image ($E-E_F = 16.9$ eV) showing the high-symmetry points of the hexagonal BZ.
 (c) Measured band dispersions of CVD-grown MoS_2 1L along the $\text{M}\Gamma\text{K}$ high-symmetry directions of the BZ and
 (d) zoom in the upper valence band (UVB) region; the blue curve represents the maximum intensity of the UVB.

All data on this page courtesy of O. Renault, CEA, LETI, MINATEC Campus, F-38054, Grenoble, France.

The NanoESCA III is distributed exclusively by Scienta Omicron. Please contact them for more informations and/or refer to the related web page <http://www.scientaomicron.com>

HAXPEEM: NANOESCA III @ HARD X-RAYS

Hard x-ray photoelectron spectroscopy (HAXPES) has now matured into a well-established technique as a bulk sensitive probe of the electronic structure due to the larger escape depth of the highly energetic electrons. In order to enable HAXPES studies with high lateral resolution, we have set up a dedicated energy-filtered hard x-ray photoemission electron microscope (HAXPEEM) working with electron kinetic energies up to 10 keV. It is based on the NanoESCA design and also preserves the performance of the instrument in the low and medium energy range. In this way, spectromicroscopy can be performed from threshold to hard x-ray photoemission.

The HAXPEEM approach is of high interest for the study of new material systems and complex device structures like nonvolatile memory cells, spin-transistors, photovoltaic elements or batteries, because it allows a spatial resolved chemical analysis of the used materials (and their electronic intermediate states) even if they are covered by electrodes which are compulsive for the functionality of these devices.

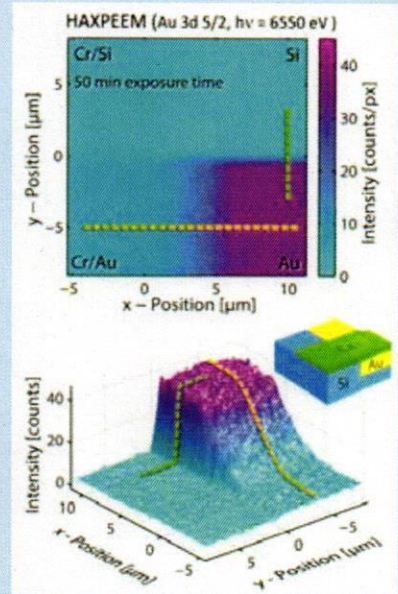

Top:

The energy-filtered PEEM image demonstrates, how the Au 3d signal is still detectable under a cover layer with increasing thickness.

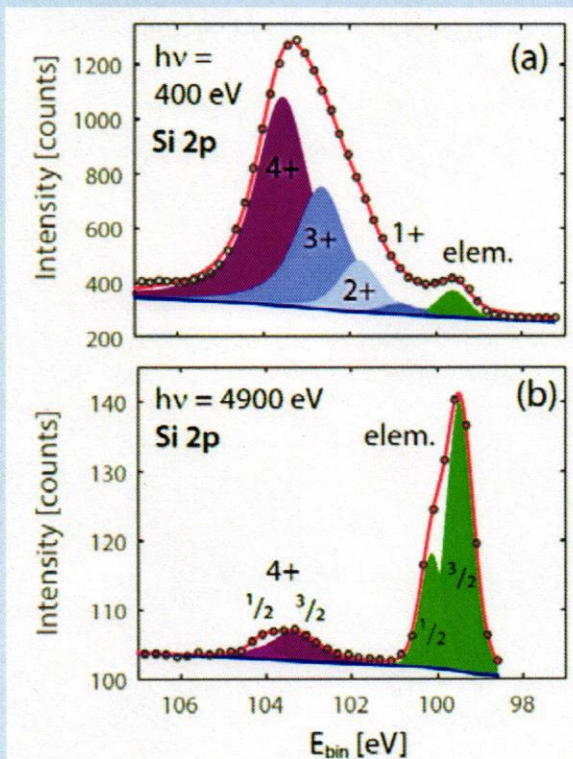

Left: Image spectra were acquired from the same Si sample with soft- and hard-x-ray synchrotron light. The measurements show, how bulk sensitivity is increased with the hard-x-ray approach.

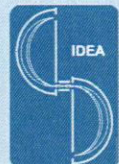

Bottom: Energy-filtered PEEM images were acquired with different excitation energies and different energy-filter settings. The HAXPEEM provides a stable image quality over a wide range of kinetic electron energies.

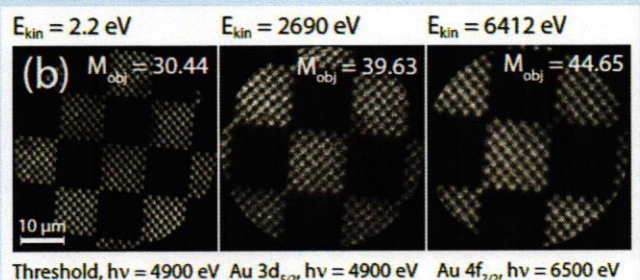

All data on this page courtesy of M.Patt, Scienta Omicron GmbH, D - 65232 Taunusstein, Germany

Ref.: Patt et al., Rev. Sci. Instrum. 85, 113704 (2014)

IMAGING 2D SPIN FILTER

For a customer specific project to perform spin polarization dependent experiments the NanoESCA III has been equipped with a dedicated 2D spin detection system /1, 2/.

This detector consists of a two-armed electron optics with an IEF system at one end. The central element is a spin sensitive scattering crystal (see left figure without the Energy filter).

In combination with the k-space optics the NanoESCA III with spin filter is collecting energy and spin resolved momentum microscope images (see right figure below).

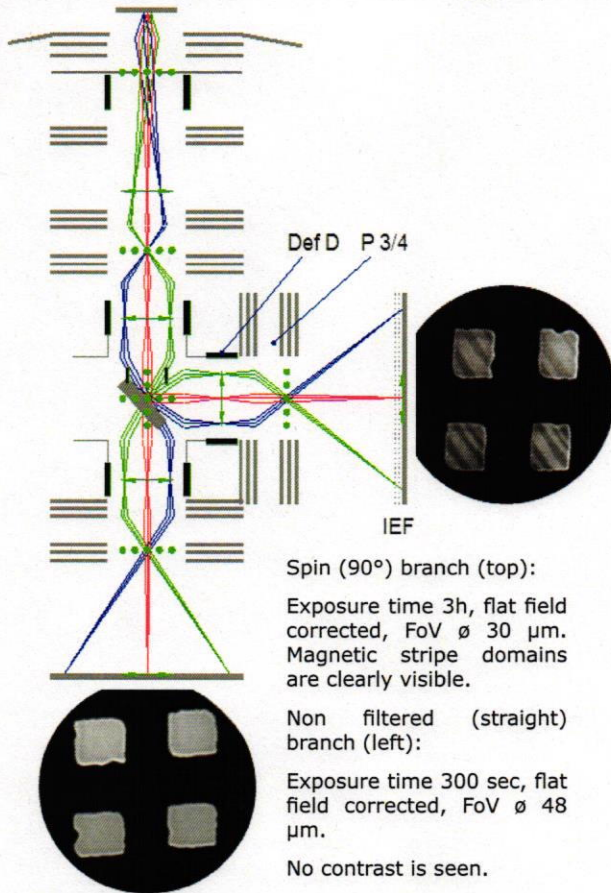

Left: The schematic set-up of first proof-of-principle experiments as performed with Hg-lamp-excitation (4.9 eV) and a non-energy filtered PEEM optics

First experiments have been done on squared Fe islands deposited onto a Si wafer sheet.

Below: The NanoESCA with the 2D spin filter attached as it has been delivered for the first prototype upgrade of a NanoESCA. The PEEM lens is not shown.

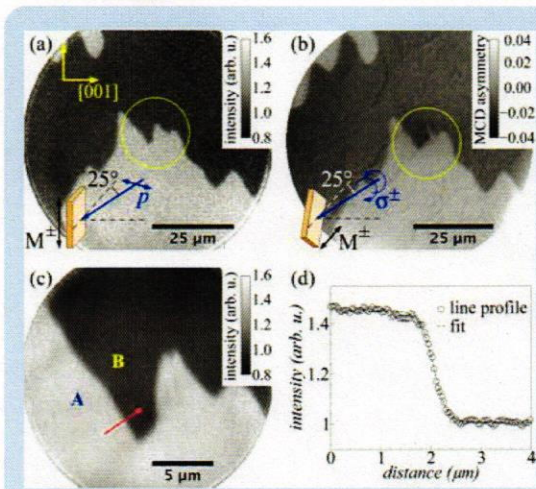
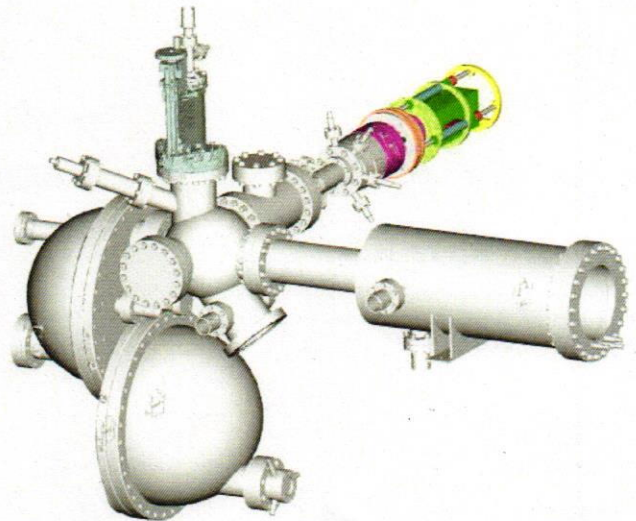

Left:

(a) Spin-filtered image of the 8 ML Co film observed after the electron beam was scattered at the W(100) crystal.

(b) The same domains imaged by magnetic circular dichroism (MCD).

(c) A high magnification image of the area marked in (a) and (b).

(d) Intensity profile across the domain wall between areas A and B. The inset in (a) and (b) shows the relative orientation of the sample, the propagation direction and polarization of the light, and the magnetic quantization axis (M6).

Reproduced from [Tusche et al., Appl. Phys. Lett. 99, 032505 (2011), doi:10.1063/1.3611648], with the permission of AIP Publishing.

/1/ Tusche et al., Appl. Phys. Lett. 99, 032505 (2011), doi:10.1063/1.3611648
/2/ Protecting German Patents: DE102005045622B4, DE102010010981B4, legal and technical rights secured by sublicensing from the Surface Concept GmbH

ProNanoESCA™: THE EASE OF USE PEEM SOFTWARE

In today's research environment the value of an analytical method is determined by its ease of use. With our software ProNanoESCA™ we've made PEEM operation as convenient and easy as possible.

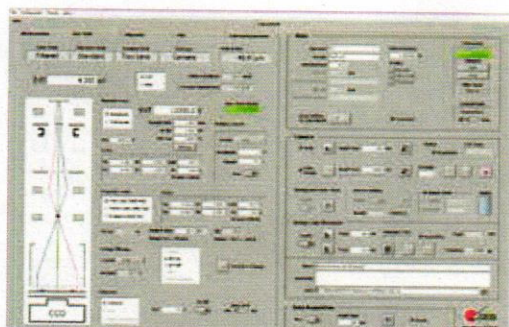

User mode

Various CCD/CMOS cameras with all imaging detectors are fully embedded into ProNanoESCA™ and provide high resolution real time imaging.

The detectors range from the standard imaging unit including the optional event counting detection system to all our energy filters like the Imaging Energy Filter(IEF), the DLD detector(TOF) and the IDEA filter (NanoESCA).

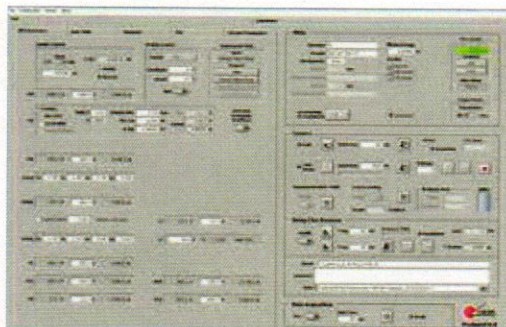

All parameters mode

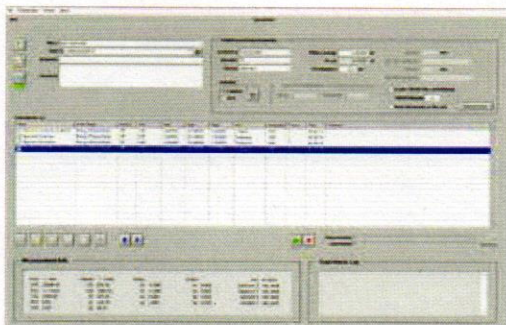

Experiment mode

ProNanoESCA™ has implemented a fully automatized lens curve and detector gain tracking: The user may zoom in and out of the image and/or change its imaged electron energy (by using energy filters) while keeping a fully focused and brightness adopted image at the same time.

Live window

This ensures ease of use with best image quality while navigating across the sample or changing the magnification. It is also an essential prerequisite for the automated acquisition of continuously well focused image stacks where every image represents a different electron energy.

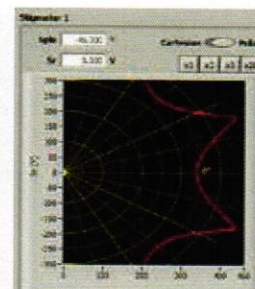
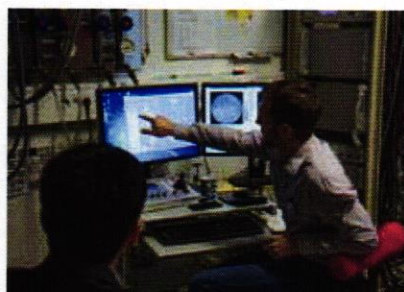
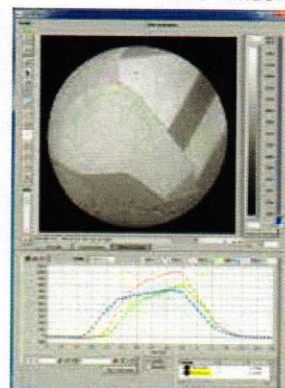

Stigmator adjustment

ProNanoESCA™ is your gate way to data acquisition, instrument control and first data evaluation. Images and spectra are saved with all instrument settings. You will have full access to all the data and parameters of a 3D image stack (or "data cube").

In addition up to 5 external parameters can be set or read like e.g. at a synchrotron the beam line monochromator energy or the polarization change.

ProNanoESCA comes along with a high performance PC platform (MS-Windows based) as a fully pre-installed plug-and-play system.

EXCITATION SOURCES

PEEM microscopy is accomplished by full frame imaging of a sample emitting electrons excited by photons (photoemission) illuminating the sample.

From this an appropriate excitation source for PEEM operation is essential and boosts the application range. The available photon source are splitting into a number of lab sources and the synchrotron based light.

In the lab the most common "workhorse" in the near UV range is a focused and heat filtered **Mercury discharge Lamp (Hg source)**. Because of its low photon energy of about 4.9 to 5.1 eV it excites very slow electrons and the PEEM is operated in the so called threshold emission regime. This enables highest lateral resolution (< 40 nm) of the PEEM also without any energy filtering.

Image contrasts are typically due to work function differences, topography, different crystallographic orientations, variation in the density of states or e.g. due to a magnetic dichroism (using polarized UV light).

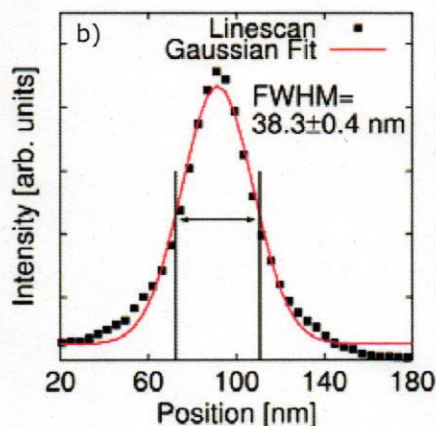
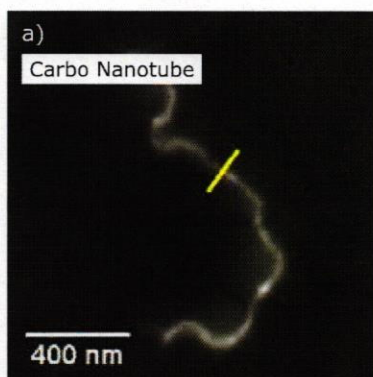

Left: Threshold image showing a single Carbon Nano Tube (CNT) taken with a Hg UV-source and highest PEEM magnification.

Line scan profile of the intensity along the yellow line in a) together with a Gaussian fit.

Ref.: Andreas Neff et al., American Journal of Nano Research and Application. Special Issue: Advanced Functional Materials. 2, 6-1, (2014), DOI: 10.11648/j.nano.s.2014020601.14

For spectroscopic PEEM operation in the valance band region and in particular for momentum microscopy a powerful **VUV line source** is essential. The VUV range from about 8.5 eV to 40.8 eV is covered nicely by a focused cold cathode discharge source. The FOCUS HIS 14 HD is optimized for this purpose. It is also available with a HeI/HeII monochromator. Typically it is operated with Helium gas enabling the excitation lines at 21.2 eV (He I) and 40.8 eV (He II).

Below: High intensity VUV source HIS 14 HD Mono to be used for monochromatic He I (21.2 eV) and He II (40.8 eV) excitation.

Right: Fermi surface of Ag(111), excited with He II excitation (HIS14 HD, 40.8 eV), $E - E_f = 40.8$ eV, dwell time 1000 s, Sample region $\sim 50 \mu\text{m}$ (NanoESCA II).

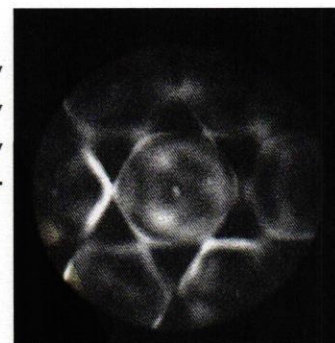
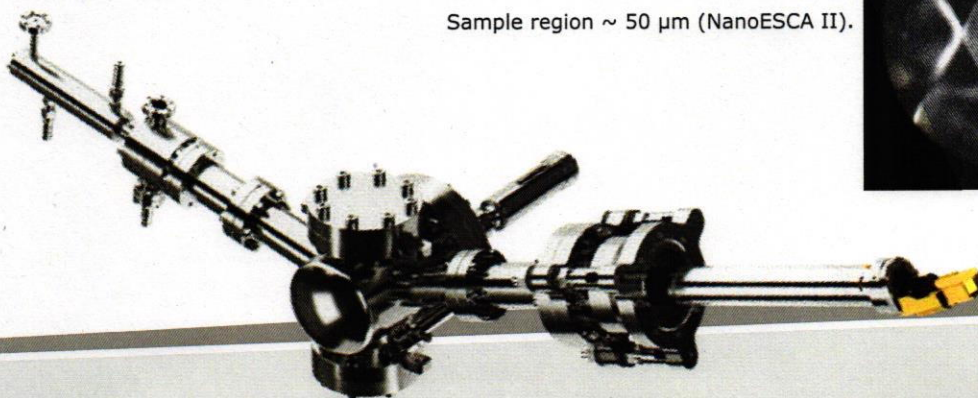

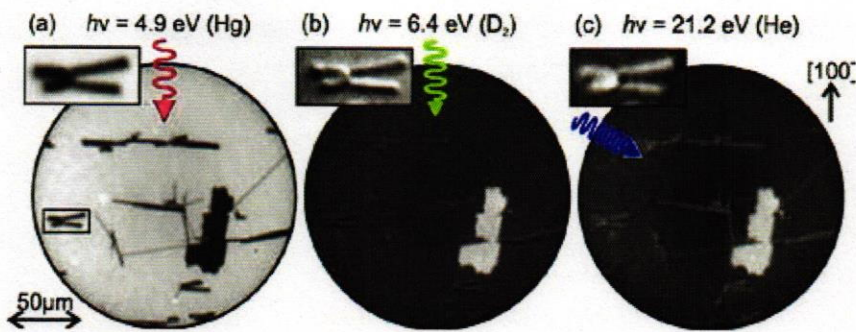

Left: PEEM images of a 33 monolayer thick film of α -6T grown at 370 K on Ag(110) using different light sources for electron excitation: Hg, D2 and HeI. FoV is about 180 μ m.

Data courtesy of Th. Wagner, Johannes Kepler University Linz, 4040 Linz, Austria.

Ref.: Th. Wagner, D.R. Fritz, P. Zeppenfeld, Organic Electronics 12 (2011) 442–446, doi:10.1016/j.orgel.2010.12.011

Also a number of both **cw and pulsed laser sources** are used today successfully with the FOCUS PEEM. Pulsed lasers are needed e.g. for time-of-flight (TOF) PEEM experiments (see page 4,5 & 7) and are a prerequisite for a number of time resolved PEEM experiments (like e.g. time resolved imaging of surface plasmons).

A highly focused and **monochromatic X-ray source** (e.g. AlK α : 1486 eV) is the prerequisite of imaging ESCA applications in the laboratory.

Except for the low energy Hg source, all the other higher energetic sources are requesting for any kind of energy filtered PEEM (see pages 4, 5 & 8).

Right:

Comprehensive spectromicroscopic study of Iodine-doped single (1L) and double (2L) layer graphene with the NanoESCA: (1) work function and (2) Iodine 3d core level analysis (AlK α X-ray lab source).

Data courtesy of O. Renault, CEA, LETI, MINATEC Campus, F-38054, Grenoble, France.

Ref.: H. Kim, O. Renault, et al., Appl. Phys. Lett. 105, 011605 (2014), doi:10.1063/1.4889747.

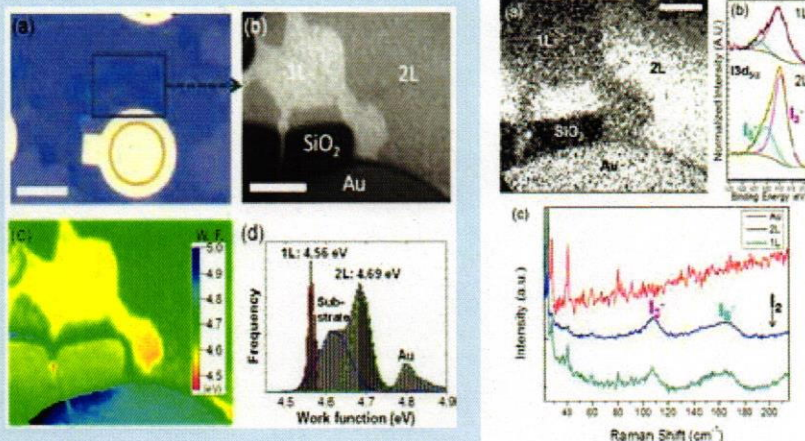

Synchrotron radiation (SR) is today the most powerful tunable light source with a wide range of photon energies (from the low eV to some 10 keV range). It allows for element specific x-ray absorption spectroscopy (XAS, total yield) also without any energy filtering. Switching of the SR light polarization is used for imaging of dichroitic contrasts like e.g. the X-Ray Magnetic Circular Dichroism (XMCD). The pulsed time structure of all synchrotrons allow for time resolved imaging and TOF experiments.

Left: Magnetic domain structure (XMCD) of a layered Cr/Fe/Ag/Fe sample imaged with PEEM using soft x-ray Synchrotron radiation (ANKA Karlsruhe); FoV: 100 μ m, Iron signal observed in photo absorption through the 3nm thick Chromium layer.

Sample: FZ Karlsruhe, Germany



DIMENSIONS

BA-Peem

IS-Peem

IEF-Peem

TOF-Peem

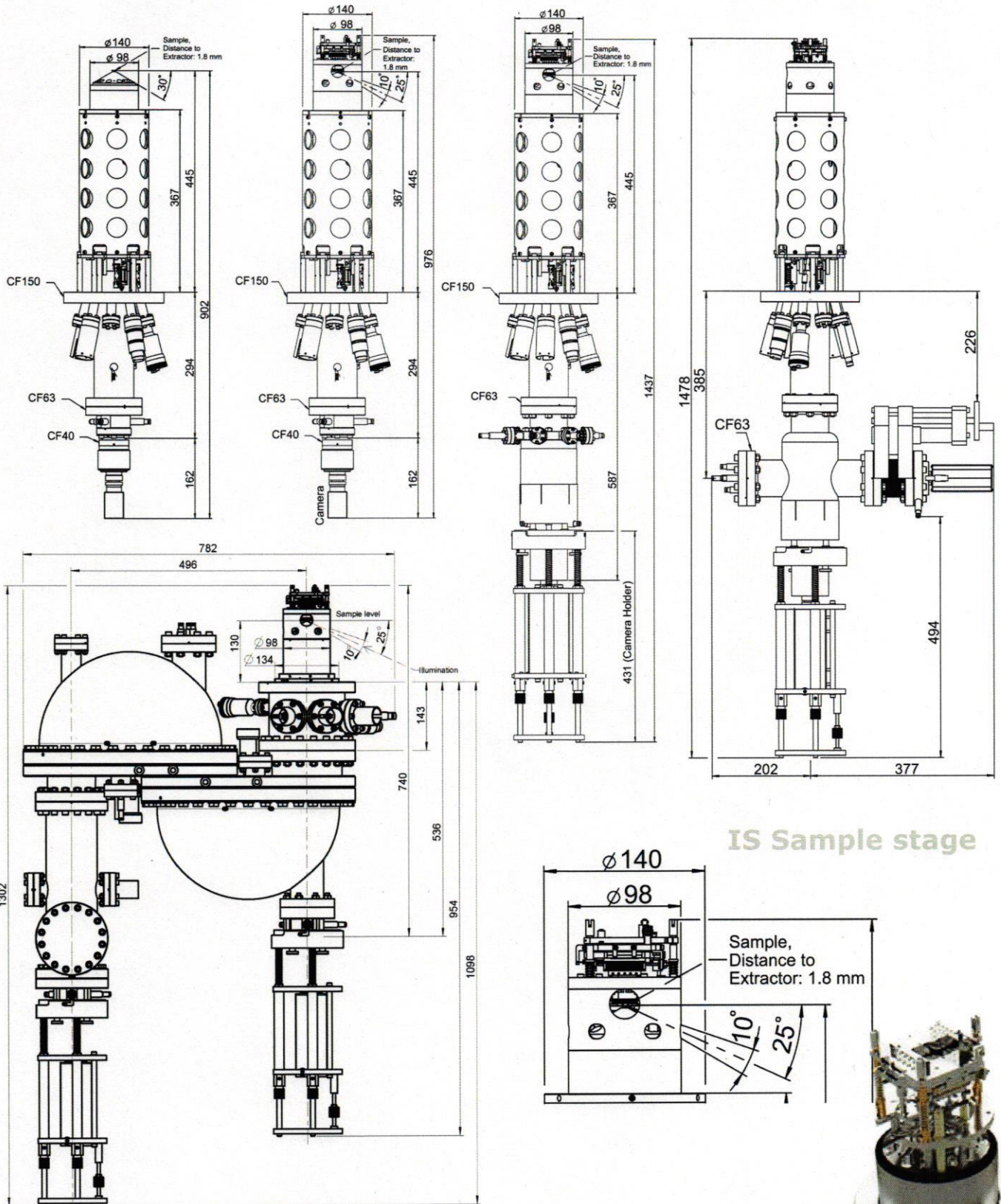

NanoESCA II



OUTFIT TABLE

	PEEM BA/BAR	IS-PEEM	IS-PEEM IEF	IS-PEEM AD IEF	IS-PEEM AD TOF	IS-PEEM AD TOF IEF	NanoESCA II (bolt-on)	HAXPEEM
Sample stage	-	integrated piezo driven x/y stage (IS stage)	integrated piezo driven x/y stage (IS stage)	integrated piezo driven x/y stage (IS stage)	integrated piezo driven x/y stage (IS stage)	integrated piezo driven x/y stage (IS stage)	integrated piezo driven x/y stage (IS stage)	integrated piezo driven x/y stage (IS stage)
x/y stage travel range	-	8x8 mm	8x8 mm	8x8 mm	8x8 mm	8x8 mm	8x8 mm	8x8 mm
Absolute position readouts	optionally (CA)	yes (CA, IS stage)	yes (CA, IS stage)	yes (CA, IS stage)	yes (CA, IS stage)	yes (CA, IS stage)	yes (CA, IS stage)	yes (CA, IS stage)
x/y precision	-	< 5µm	< 5µm	< 5µm	< 5µm	< 5µm	< 5µm	< 5µm
Sample bias	ext. up to 2kV	ext. up to 2kV	-20V ... +1.600V	-20V ... +1.600V	-20V ... +1.600V	-20V ... +1.600V	-20V ... +1.600V	-20V ... +10.000 V
Sample heating /cooling	-	on request	on request	on request	on request	on request	on request	on request
Extraction voltage	50 V ... 16 kV	50 V ... 16 kV	50 V ... 16 kV	50 V ... 16 kV	50 V ... 16 kV	50 V ... 16 kV	50 V ... 16 kV	50 V ... 24 kV
Normal incidence	optionally	optionally	optionally	optionally	optionally	optionally	optionally	optionally
Contrast aperture (CA)	70, 150, 300, 500, 1750 µm	70, 150, 300, 500, 1750 µm	70, 150, 300, 500, 1750 µm	70, 150, 300, 500, 1750 µm	70, 150, 300, 500, 1750 µm	70, 150, 300, 500, 1750 µm	70, 150, 500, 850, 1750 µm	70, 150, 500, 850, 1750 µm
Iris aperture (IA)	optionally	yes	yes	yes	yes	yes	yes	yes
Real space Field of view(r-FoV)	3 ... 800 µm	3 ... 800 µm	2.5 ... 600 µm	2.5 ... 1700 µm	2.5 ... 1700 µm	2.5 ... 1700 µm	6 ... 800 µm	6 ... 800 µm
achievable Lateral resolution	< 40 nm	< 35 nm	< 35 nm	< 35 nm	< 35 nm	< 35 nm	< 35 nm	< 35 nm
k-space imaging	-	-	no	yes	yes	yes	yes	yes
k-space Field of view(k-FoV)	-	-	-	> 6 Å ⁻¹	> 6 Å ⁻¹	> 6 Å ⁻¹	> 6 Å ⁻¹	> 6 Å ⁻¹
Energy filter	no	optionally	retarding field (IEF)	retarding field (IEF)	time-of-flight (TOF)	retarding field (IEF) and retractable time-of-flight (TOF)	imaging double hemispheres (IDEA, patented)	imaging double hemispheres (IDEA, patented)
Energy range (E-E_F)	-	-	0 ... 1.595 eV	0 ... 1.595 eV	0 ... 1.595 eV	0 ... 1.595 eV	0 ... 1.595 eV	0 ... 10.000 eV
achievable Energy resolution	-	-	< 50 meV	< 50 meV	< 30 meV	< 50 meV (IEF) < 30 meV (TOF)	< 25 meV	< 25 meV
achievable k-space resolution	-	-	0.018 Å ⁻¹	0.018 Å ⁻¹	0.018 Å ⁻¹	0.018 Å ⁻¹	0.018 Å ⁻¹	0.018 Å ⁻¹
achievable Time resolution	-	-	-	-	< 150 psec	< 150 psec (TOF)	< 150 psec (if combined with TOF)	< 150 psec (if combined with TOF)
Single MCP (SMCP)	yes	yes	no	no	yes	no	no	no
Double MCP (DMCP)	optionally	optionally	yes	yes	no	yes (IEF)	yes	yes
CCD camera standard (60sec/frame ...25 frames/sec)	yes	yes	optionally	optionally	optionally	optionally	optionally	optionally
Slow scan CCD camera (900sec/frame ...50 frames/sec)	optionally	optionally	optionally	optionally	optionally	optionally	optionally	optionally
S-CMOS camera (1msec ...10 sec/frame; up to 140 frames/second)	optionally	optionally	yes	yes	yes	yes	yes	yes
Event counting	optionally (DMCP needed)	optionally (DMCP needed)	yes	yes	optionally (DMCP needed)	optionally (DMCP needed)	optionally	optionally
Spin detection	n.a.	n.a.	n.a.	n.a.	n.a.	n.a.	on request	on request
Software ProNanoESCA™ and PC	plug & play	plug & play	plug & play	plug & play	plug & play	plug & play	plug & play	plug & play

Note: Design and specifications will constantly be improved and thus be subject to technical progress.

Please feel free to contact us for all detailed questions!

For a quotation please refer to your local Scienta Omicron agent.

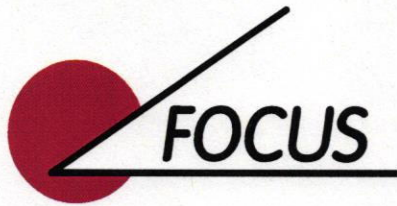
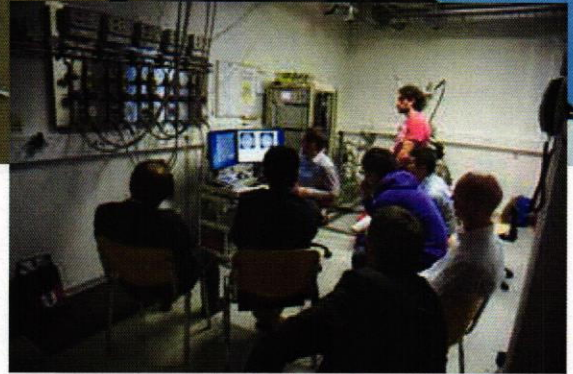

FOCUS is an owner-managed German company situated in Hünstetten only 30 min drive away from Frankfurt airport.

Since its foundation in 1990, FOCUS develops and builds scientific instruments in the field of electron spectroscopy and electron microscopy, in close co-operation with several universities and research centers as a platform for new and innovative products.

Those products are developed, manufactured and tested in-house. This holds for most of the vacuum components as well as the related electronics, software and the electron optics. Special value is set on software development and intelligent control concepts to combine ease of use with most recent technology. A dedicated team of electronic engineers, software engineers, designers and physicists, in co-operation with external partners, ensures that FOCUS products always meet the latest demands of the high technology branches in long term.

The scientific instruments of the FOCUS product range include electron beam evaporators, electron spectrometer and the patented NanoESCA, an energy dispersive microscope to image photoelectrons.

With its sound foundation of long experience in the development and construction of electron beam devices, FOCUS has entered the field of electron beam welding in 2007 and has firmly established itself since then with the Micro electron beam welder MEBW-60 (see also: focus-e-welding.com).

Visit our webpage

www.focus-gmbh.com

for detailed and up to date product information.